

**ULTRASOUND FLOWMETER
SONIX 10D**

INSTRUCTIONS FOR ASSEMBLY AND OPERATING

SONIX®
Industrial Electronic Devices
mgr inż. Krzysztof Kołodziej
ul. Leopolda Lisa-Kuli 12, 05-270 Marki, Poland
phone:+48 22-7811133, fax: +48 22-7811644
www.sonix.com.pl

Contents

INTRODUCTION.....	3
Component parts	3
List of supplied elements.....	4
Purpose	4
Basic technical data	4
ASSEMBLY.....	5
Mechanical assembly of the flow sensor	5
Measurement example of sewage flow in a gravitational pipeline	5
Length of straight sections of the pipeline.....	5
Recommendations for the flow sensor assembly.....	6
The producer's supervision over the assembly and start-up	6
Space for the assembly of ultrasound probes	6
User's preparation for assembly	7
Assembly of the measuring transducer.....	7
Electrical Connections	8
OPERATING.....	8
General Information	8
Descriptions of the menu.....	9
E0 Flow Volume.....	9
E1 Upper threshold Lower threshold.....	9
E2 Diagnostic screen.....	10
E3 Working time Time of correct work.....	10
E4 SONIX.....	10
User's functions.....	10
Negative volume.....	10
Password change.....	10
Starting the backlight.....	10
Change of current and range.....	10
Setting the thresholds.....	10
Change of display precision	11
Change of the constant of time, calibration of the current output	11
Parameters of the RS485 output.....	11
Exiting user's functions.....	11
Temporary volume.....	11
Servicing functions.....	11
ERRORS.....	11
General information.....	11
Diagnostic messages.....	11
THE SERIES RS485 OUTPUT.....	12
Protocol description.....	12
Electrical connections.....	12
Unit change over – volume/mass	12
List of registers.....	13
THE SONIX P5 READING PANEL.....	14
General information.....	14
Mechanical assembly.....	14
Electrical connections.....	14
Operating	15
DECLARATION OF COMPLIANCE.....	16
GUARANTEE CERTIFICATE	17

The producer reserves the right to change the products in order to increase their utility values or adjust them to current regulations. Such changes may not be taken into account in the current version of the instruction ©SONIX2004 Act. 29.08.2005

INTRODUCTION

Component parts

The SONIX 10D flowmeter consists of a flow sensor and a measuring transducer connected to it with cables. The flow sensor is available in three versions:

1. A U-shaped section ended with flanges or a screw thread (DN15...40)
2. A section ended with flanges (DN50...1200)
3. An existing section of a pipeline (DN250...2000)

Additional equipment:

- The SONIX P5 reading panel
- The SONIX S5 flow simulator
- Probes exchangeable under pressure for versions 2 and 3 (from DN200)

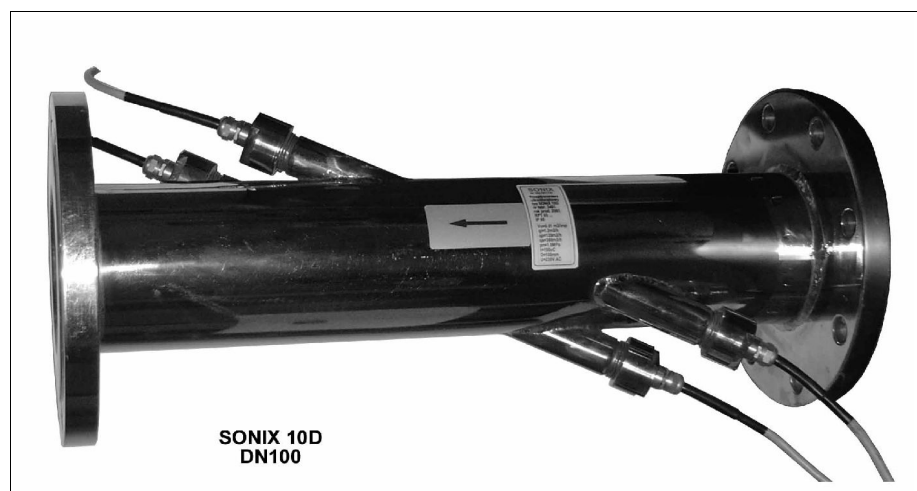
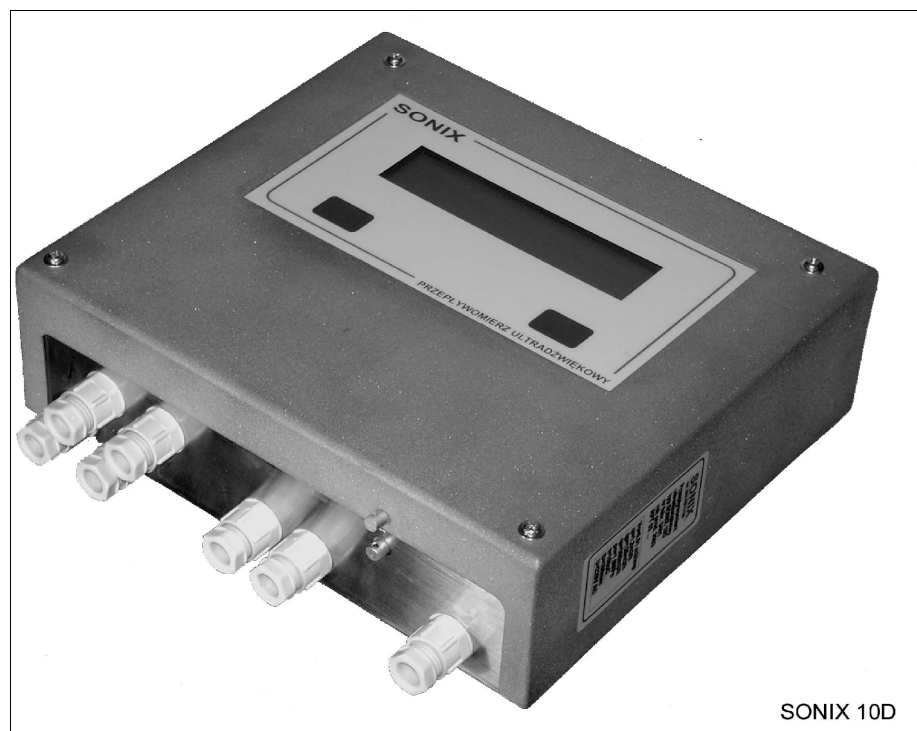

List of supplied elements

The following elements constitute the flowmeter set:

- a measuring transducer
- a flow sensor with two or four ultrasound probes including cables
- Instructions for Assembly and Operating and a Guarantee Certificate
- Calibration certificate for the flowmeters calibrated in the SONIX company flow stand

Purpose

Measurement of flow intensity and summing the volume of flowing liquids in closed fully filled pipelines.

Flow transducer for a heat meter.

Cold water meter.

Flow meter for industrial usage not requiring verification.

Basic technical data

	Flow transducer for heat meter	Cold water meter	Flow meter not requiring verification
Authentication type	Decision No ZT 229/2004		-
Mark of authentication type	PLT 0436		-
Diameter range of pipelines (mm)	50 ÷ 600	50 ÷ 300	15 ÷ 2000
Liquid speed range (m/s)	0,038 ÷ 5	0,038 ÷ 4	0 ÷ 15
Liquid temperature range (°C)	0 ÷ 130	0 ÷ 30	0 ÷ 150 temporarily to 180
Surrounding temperature of the measuring transducer	0 ÷ 55	0 ÷ 55	0 ÷ 55
Liquid reaction (pH)	3 ÷ 11	3 ÷ 11	3 ÷ 11
Working pressure (MPa)	0,03 ÷ 2,5	0,03 ÷ 2,5	0,03 ÷ 2,5 (4)
Basic measurement error (% w.m.)	$\sigma = \pm 0.5$	$\sigma = \pm 0.5$	$\sigma = \pm 0.5$
Method of calibration or verification	Verification with cold or hot water on the flow stand in the verification premises	Verification on the flow stand in the verification premises	Calibration in the flow stand of the SONIX company. Flowmeters assembled on an existing pipeline-theoretically calibrated in accordance with the Polish PN/M-42370 Norm

ASSEMBLY

Mechanical assembly of the flow sensor

The choice of location and manner of the assembly of the flow sensor decides on the metrological properties of the device.

The following conditions must be met in order to provide correct measurement:

1. Lack of aeration of the liquid
2. 100% filling of the pipeline
3. Small suppression of the sound wave
4. Stabilized and symmetrical profile of liquid speed

The U-shaped sensor must be assembled horizontally or at the 45° angle max. The assembly position of the remaining type of sensor depends on the choice of the user. The probes must be located in the horizontal surface i.e. at both sides of the pipeline and not below and above it. The acceptable deviation from the level equals 25°.

Measurement example of sewage flow in a gravitational pipeline

The elements of the measuring system shown on the following figure provide the conditions necessary for correct measurement:

- Deaeration of the inflowing sewage
- 100% filling of the pipeline
- Lack of accumulating deposit in the flow sensor
- Symmetrical profile of liquid speed

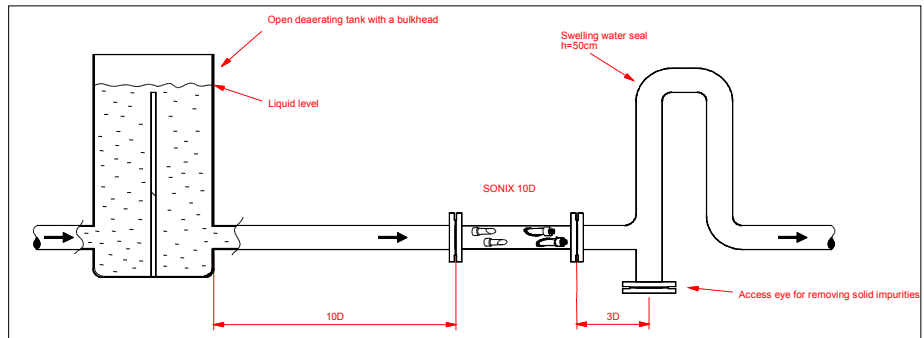

Length of straight sections of the pipeline

In the majority of cases, straight sections of the following lengths are sufficient:

- Inlet: 10D
- Outlet: 3D

Two- or more surface spatial configurations of the pipeline, the pump, not entirely closed valves, side inlets etc. require appropriate elongation of the straight sections before and behind the measuring spot. The U-shaped flow sensor does not require straight sections.

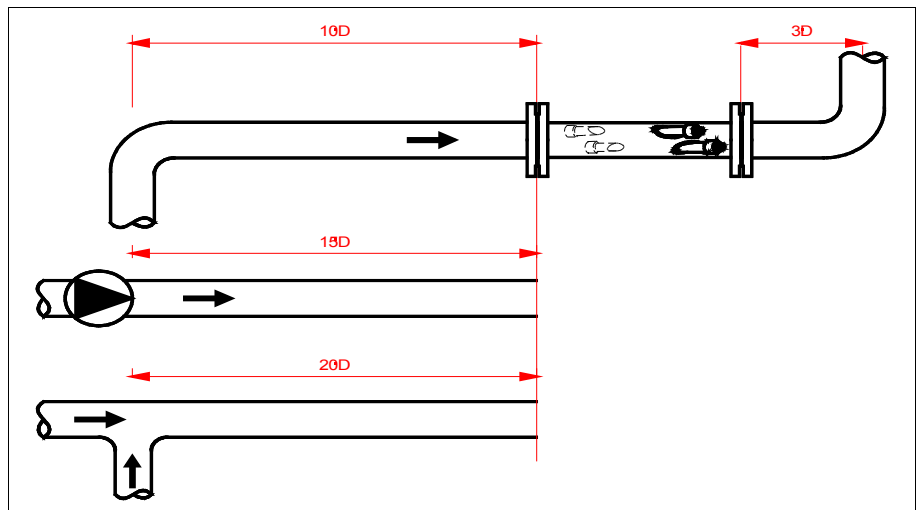

Recommendations for the flow sensor assembly

Choose the longest available straight section of the pipeline. Install the sensor with probes on the 3/4 of its length starting from the outwash. Make sure that in the selected spot the liquid will not be aerated and air or solid impurities will not accumulate there.

The inside diameter of the pipeline and the sensor should be the same. Install the sensor in such a way so the arrow on it is on top and shows the flow direction.

The probes should be located horizontally on both sides of the pipeline (never vertically).

The seals of the flange connections cannot protrude into the inside of the pipeline (protruding seals cause the increase of measurement error from ± 5 to $\pm 40\%$)

Do not hit the flow sensor with a hammer or other devices. It may damage the probes.

The factory numbers of the measuring transducer and the sensor must be identical.

Place the measuring transducer in a place appropriate for readings from the display and accessible for servicing team.

Run the signal and feeding cables in separate, own channels and attach them to the terminal strip of the flowmeter in accordance with the markings and colours.

The length of the cable between the PE terminal of the flowmeter and the grounding vertical should not exceed a few metres.

The producer's supervision over the assembly and start-up (refers to assembly on an existing pipeline DN250...DN2000)

The following activities make up the assembly and the start-up of the flowmeter:

- Routing of the pipeline
- Making 4 openings of approx. 30mm diameter in the wall of the pipeline (acetylene cutting in a steel pipeline, drilling in a cast iron one)
- Electronic welding of attaching sleeves to the steel pipeline or screwing them to a cast iron one
- Assembly of ultrasound probes
- Assembly of the measuring transducer
- Connecting the measuring transducer to the ultrasound probes with transmission cables
- Start-up of the flowmeter

Setting to zero in the case of stopped flow

Space for the assembly of ultrasound probes

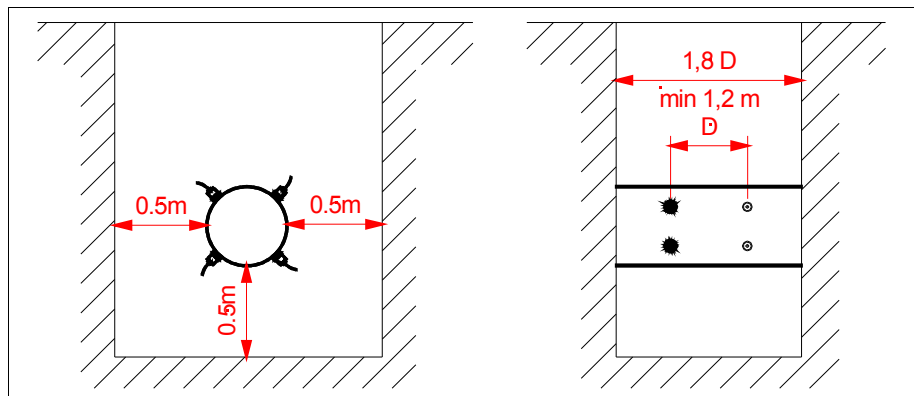

User's preparation for assembly

Choice of the measuring spot on the pipeline and choice of measuring transducer location. In case of doubts, it is recommended to consult a SONIX representative. Preparation of the pipeline for assembly:

-cleaning the surface of the pipeline from rust, insulation etc on the whole of its circumferences on the length of 1.8D

-emptying the pipeline for welding and probe assembly.

The tentative emptying time equals approx. 2 hours for a steel pipeline and approx. 6 hours for a cast iron one.

-Filling the pipeline in order to start-up the flow meter. After the filling, it is recommended to stop the flow for approx. 10 min in order to set the flowmeter to zero.

Acetylene cutting of openings of approx. 30mm diameters and electrical welding for a steel pipeline.

Preparation of possible seal wires, tubes, channels etc. for running transmission cables for the probes: four cables of the approx. 6mm diameter.

Connecting the 230V AC or 24V AC feeding and the signal cables to the measuring transducer.

Assembly of the measuring transducer

It is acceptable to assembly the device in the open air in a heated protective cabinet. Due to temperature range of 0-55 C during the summer months, the cabinet should be located in the shadow.

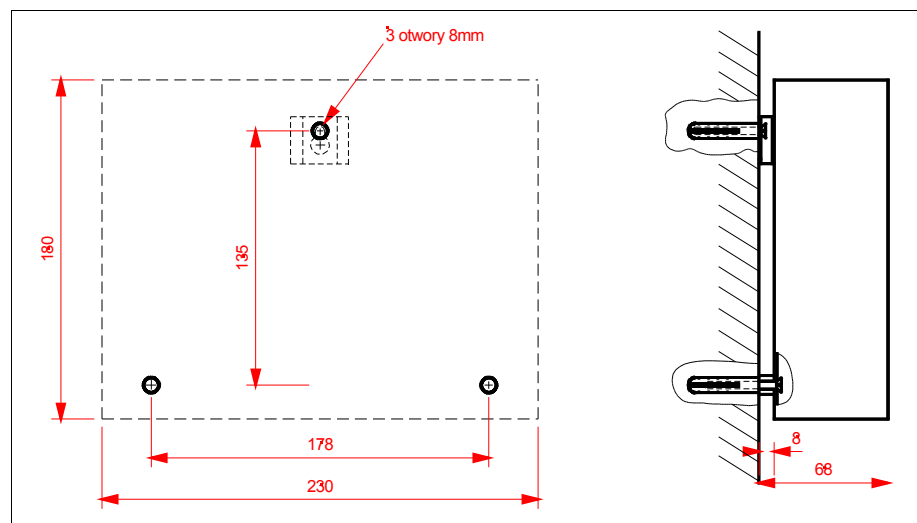

Electrical Connections

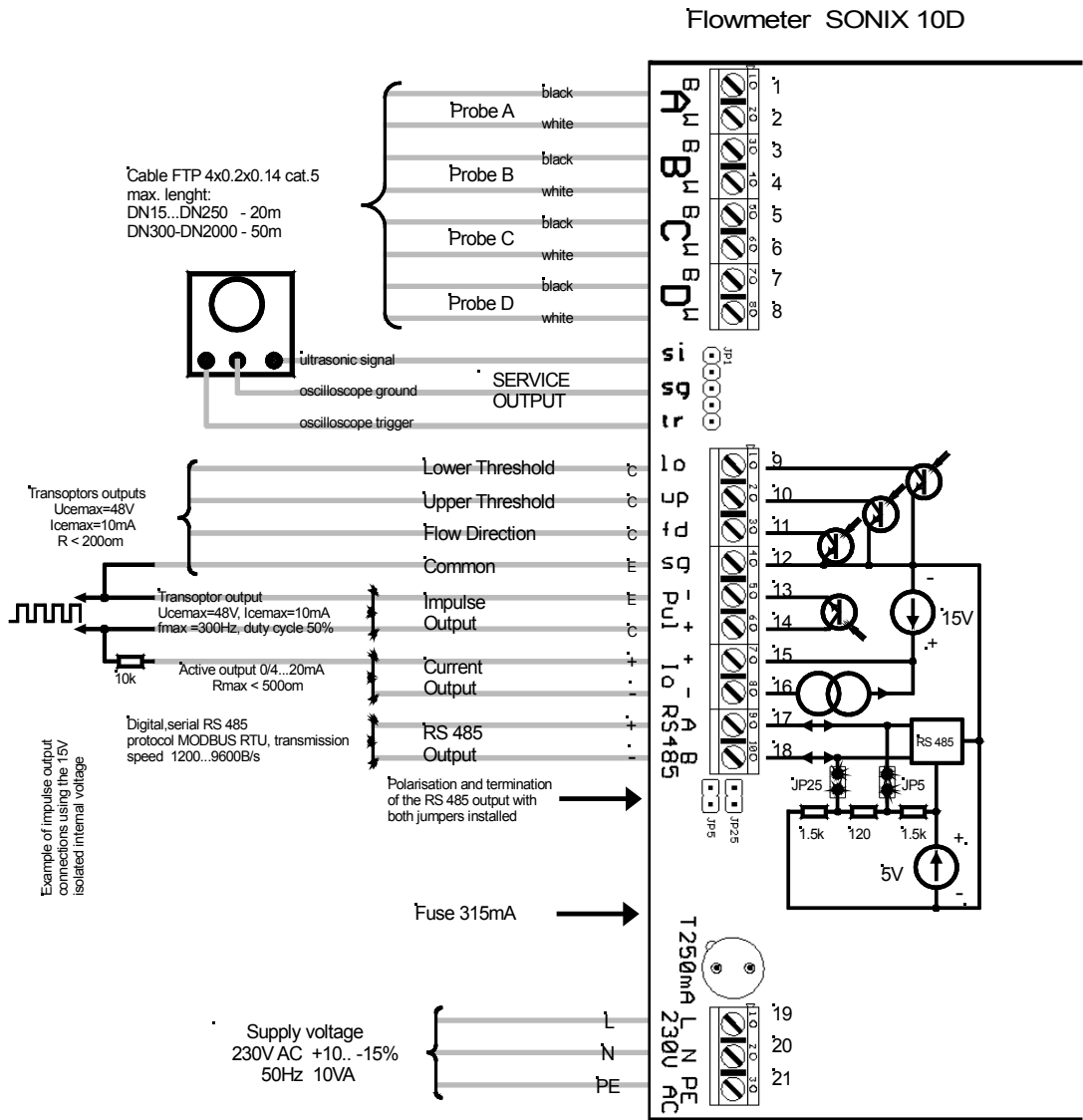

OPERATING

General Information

The user communicates with the device via the LCD 2x16 characters display using two push buttons of his choice and changes of functions or parameters. The principle of operating the push buttons is as follows

- The left one 'L': choice of function or digit
- The right one 'P': change of function or value
- Left and right one at the same time 'O': accepting the change

The menu consists of 5 basic screens and user's and servicing functions.

Descriptions of the menu

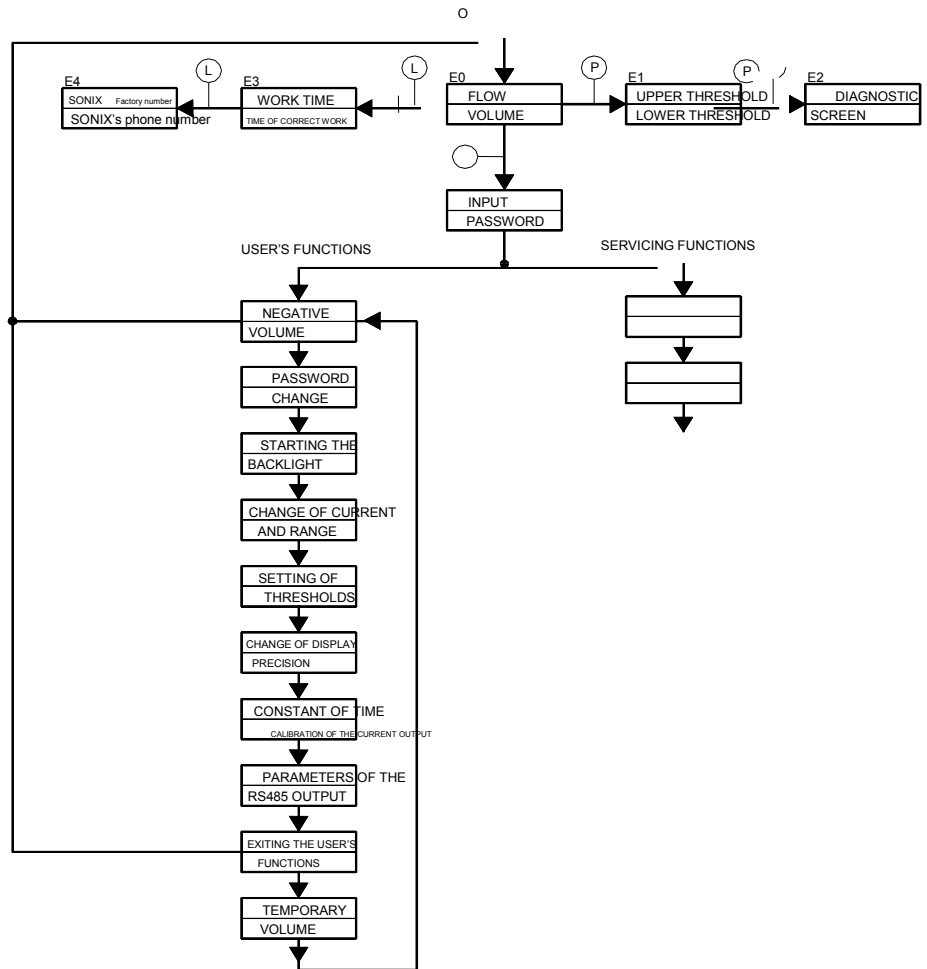

**E0
Flow
Volume**

The current flow in m³/h (or t/h) and the counted volume in m³(or t). Counted by the basic volume counter for positive flow. Counted by a separate negative volume counter available in the user's functions for negative flow. Power failure does not cause deletion of volume counter data or the loss of other data and parameters. It is possible for the user to program the number (0...3) of displayed decimals.

**E1
Upper threshold
Lower threshold**

Monitoring of the programmed temporary flow thresholds above and below which a short circuit of appropriate transistors in transoptor outputs takes place. Threshold programming is available in the user's functions.

E2 Diagnostic screen

Upper line, from left:
 -Flow speed in m/s
 -Type and value of enhancing adjustment: r-manual adjusting, a-automatic adjusting
 -Mode of work: 0 – lack of liquid
 1– two path measurement, work only on the AB path
 2– two path measurement, work only on the CD path
 3– two path measurement, work on both paths
 4– one path measurement - AB
 5– one path measurement - CD
 - the percentage of interferences marking the ratio of the number of incorrect flow measurements to all measurements done within a unit of time. Values below 25% are satisfactory. Values between 25...50% show excessive electrical interferences or liquid aeration. Values above 50% are treated as group I errors requiring servicing.

Diagnostic messages are displayed in the lower line:

'Correct measurement'
 'Lack of liquid' – empty pipeline or disconnected probes
 'Weak AB signal' – decreasing of the signal from the AB pair of probes
 'Weak CD signal' – decreasing of the signal from the CD pair of probes CD
 'Out of range I' – flow exceeding the current range
 'Out of range v' – too high liquid speed
 'Interferences' – more than 50% of interfered measurements
 'Wrong parameter' – incorrect parameter value introduced
 'Damage of the AB probe' – damage of one or both probes of the AB pair
 'Damage of the CD probe' – damage of one or both probes of the CD pair
 'Damage' – damage of the digital part of the flowmeter
 'Temperature?' – lack of temperature record (in the case of tone display)

E3 Working time Time of correct work

Working time means the number of hours the feeding of the machine was on. Time of correct work means the number of hours without signaling errors of group I or II.

E4 SONIX

Logo of the SONIX company. Factory number of the flowmeter. Phone number of SONIX's service.

User's functions

Using the user's functions does not influence flow measurement and volume counting done at the same time by the flowmeter. The impulse output remains free from interference as well.

Negative volume

Dodatkowy licznik zliczający objętość (lub masę) przepływającej cieczy w czasie gdy kierunek przepływu jest ujemny.

Password change

5 digit access password to user's functions. Default password 11111

Starting the backlight

The LCD display is backlit for 15s after pressing any push button

Change of current and range

Change of output current 0/4mA
 Programming of range flow in m³/h or t/h.
 Programming the characteristics of the current output:
 + the output works symmetrically for the negative and positive flows
 - the output work solely for the positive flow

Setting the thresholds

Programming of the lower and upper flow threshold in m³/h or t/h.

Change of display precision	Programming from 0 to 3 decimals for temporary flow and the summed volume.
Change of the constant of time, calibration of the current output	Change of the measurement's constant of time: 0...9 corresponds to approx. 0.5...30s. Forcing the 0, 4, 10, 15 or 20mA current in the current output in order to achieve calibration connected to the current output of the device.
Parameters of the RS485 output	Programming parity control: Odd, Even, None, address of the device: 01 _H ...FF _H and transmission speed: 1200B/s...9600B/s.
Exiting user's functions	Exiting user's functions is done by pressing both push buttons or moving to temporary volume by pressing the left push button.
Temporary volume	The function allows dosing the liquid. The temporary liquid counter is set to zero and initiated with the left push button and stopped with the right one. The counter may also be operated by the RS485 series link (see Protocol of series transmission).
Servicing functions	The functions are accessible only by the SONIX servicing team.

ERRORS

General information	<p>Errors in the work of the flowmeter are divided into two groups:</p> <ol style="list-style-type: none"> I. Errors causing incorrect measurement and requiring immediate servicing. The occurrence of such error is signaled by periodical blanking of the display every 0.3s. All outputs return to non-active states. Volume counting and the counter of correct work are blocked. The description of the error is displayed on the diagnostic screen. II. Errors of lesser importance which do not influence the accuracy of measurement but require servicing within a few weeks or months. The occurrence of such error is signaled by periodical blanking of the display every 4s. All functions and outputs remain active. The description of the error is displayed in the diagnostic screen.
Diagnostic messages	<p>Correct measurement: the measurements are done correctly.</p> <p>Errors:</p> <p>Group I – errors of high importance (blanking of the display every 0.3s)</p> <ul style="list-style-type: none"> -damage of the measuring transducer -damage of the probes or cables except for damage of one pair of probes in two-path work. The flowmeter then switches over to the functioning pair of probes and an error of group II is signaled -too high speed of the liquid -pipeline not fully filled -too many interferences -introduction of an incorrect value of a parameter <p>Group II – errors of lesser importance (blanking of the display every 2s)</p> <ul style="list-style-type: none"> -poor ultrasound signal -flow outside the current range -damage of one pair of probes in two-path work -lack of temperature records by the RS485 link when tones are the programmed unit. m³ then remains the unit and an error is signaled.

THE SERIES RS485 OUTPUT

Protocol description

The MODBUS RTU protocol of series transmission is compliant with the current specification available at www.modbus.org. Transmission speeds: 1200, 2400, 4800 or 9600 B/s. Addresses of the devices: 1 ...255.

Character format:

- 1 start bit
- 8 data bits
- 1 parity control bit (programmable: Odd, Even, None)
- 1 stop bit (or 2 stop bits when programmed to None).

Two functions are available:

03 or 04 – reading of the content of the flowmeter's register group 06 – recording data in the flowmeter register **Examples of frameworks for the device of the 02_H address**

1. Reading of 2 registers beginning from register no 10 of the following content:
register no 10: 057F_H register no 11: 9D1A_H
Order: 02,03,00,09,00,02,14,3A
Response: 02,03,04,05,7F,9D,1 A,11,7C
2. Setting to zero and starting the temporary volume counter:
Order: 02,06,00,1 E,00,01,28,3F
Response: 02,06,00,1 E,00,01,28,3F
3. Stopping the temporary volume counter:
Order: 02,06,00,1 E,00,00,E9,FF
Response: 02,06,00,1E,00,00,E9,FF
4. Record of the 94°C temperature in register no 32:
Order: 02,06,00,1 F,00,5E,39,C7
Response: 02,06,00,1 F,00,5E,39,C7

Electrical connections

The applied isolated interface is compliant with the EIA RS-485 standard. The transmission line must be connected in accordance with labels on the printed plate: R_A – higher potential, R₃ – lower potential. In the case of severe electrical interferences or of the length of the cables exceeding 300m, one should use the "spiral" type of cable of the 120Q, cat.4 wave resistance. If the flowmeter is located at the end of a transmission line exceeding 300m, one should initiate the 120Q line load by using the JP5 and JP25 armatures (next to the fuse on the printed plate). Simultaneously with the load, the line is also polarized with the approx 2.5V voltage. (see Electrical connections of the flowmeter). The flowmeter is supplied with armatures attached.

Unit change over – volume/mass

The SONIX 10D flowmeter enables readings of temporary values of the flow and the content of counters in mass units (t/h, t and kg). In order to achieve this, one should: 1. Program the desired option in the servicing functions (done by the SONIX servicing team) 2. Record in register 32 the current temperature value in the char. format via the RS485 interface. Available temperature range: 1 ...255°C Remarks:

- Temperature records must be done not less frequently than every 100s. If this is not done, the device will return to displaying in volume units at the same time signaling an error. The content of the counters will not be deleted.
- The change over into mass units does not apply only to the impulse output of the flowmeter.

List of registers

Register no	Variable type		Name of the variable
1	float	LO	Flow m ³ /h (t/h)
2		HI	
3	long int	HI	Positive volume m ³ (t)
4		LO	
5	int		Positive volume l(kg)
6	float	LO	Liquid speed m/s
7		HI	
8	bit		errors 1... 16
9			reserved
10			reserved
11	long int	HI	Working time s
12		LO	
13	long int	HI	Time of correct work s
14		LO	
15	long int	HI	Temporary volume l(kg)
16		LO	
17	long int	HI	Negative volume m ³ (t)
18		LO	
19	int		Negative volume l(kg)
20	float	LO	5 min average of the flow
21		HI	
22	float	LO	Hour average of the flow m ³ (t)
23		HI	
24			Reserved
25			Reserved
26			Reserved
27			Reserved
28			Reserved
29			Reserved
30			Reserved
31	bit		Op. with temp. vol. counter
32	char		Temperature oC

Remarks:

16 bit registers, char, int, long int – variable without a character

Register no 8 (errors), 1 in a given position means:

15 - reserved

14 - reserved

13 - reserved

12 - reserved

11 - reserved

10 - lack of temperature record to register no 32

9 - weak signal from the CD pair of probes

8 - outside the range of acceptable liquid speed

7- damage of the digital part of the flowmeter

6 - the flow exceeds the programmed range value

5 - excessive number of electrical interferences or aeration of the liquid

4 - damage of a probe in the CD pair

3 - damage of a probe in the AB pair

2 - incorrect value of a parameter programmed

1 - lack of liquid in the pipeline, damaged probe cables, damage of the analogue part of the flowmeter

0 - weak signal from the AB pair of probes

THE SONIX P5 READING PANEL

General information

The reading panel enables additional readings and using all the functions of the flowmeter in a large distance from the measuring spot. It is designed for one flowmeter-one reading panel work configuration.

The RS485 output of the flowmeter is used which is programmed in the following way:

Parity control - None (no parity control)

Address-001

Transmission speed - 2400B/S

The series RS485 output of the reading panel has the same parameters and services the same orders of the MODBUS RTU protocol as the series RS485 output of the flowmeter.

The casing of the reading panel is to be fixed board-like in a standard opening.

Mechanical assembly

Criteria for selecting the place to assembly the reading panel:

- the length of the cable leading to the flowmeter must not exceed 1000m
- range of environment temperature 0 - 55°C
- convenient reading from the display should be available

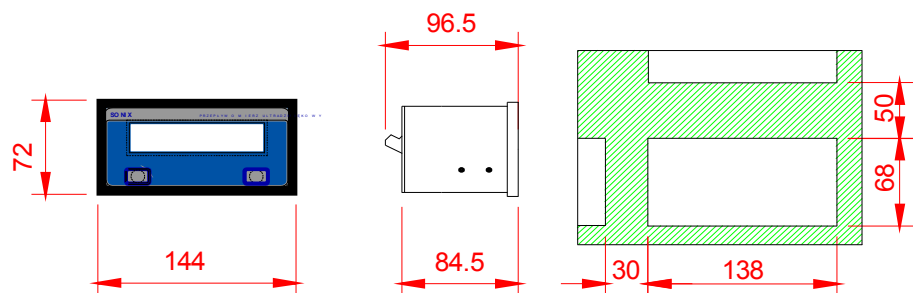

Electrical connections

The panel must be connected to the flowmeter with a twin cable in accordance with the figure below. In the case of severe electrical interferences or if the length of the cables exceeds 300m, one should use the "spiral" type of cable of the 120Q, cat.4 wave resistance or a screen spiral. The screen must be attached to the PE terminals on both sides of the cable.

The series RS485 output of the panel is supplied with JP3 and JP4 armatures installed which attach 2.5V polarization and 120Q load to the line. In order to remove the armatures, one must unscrew the back wall of the casing. Feeding voltage of the panel: 230V AC $\pm 10\%$. Input power: 1VA.

DECLARATION OF COMPLIANCE

The producer:
SONIX® Industrial Electronic Devices
ul. Leopolda Lisa-Kuli 12, 05-270 Marki

declares that the following described product:
SONIX10D

is compliant with the requirements of the European Union directive no
73/23/ECC, 93/68/ECC, 89/336/ECC, 97/23/EC

and is compliant with the principal requirements contained in the following
norms:

PN-EN 61000-4-2:1999; PN-EN 61000-4-3:2002; PN-EN 61000-4-4:1999;
PN-EN 61000-4-5:1998; PN-EN 61000-4-8:1998; PN-EN 61000-4-11:1997;
PN-EN 55022:2000; PN-EN 1434-1:1997; PN-EN 1434-4:2001; PN-EN
60068-2-2; PN-EN 60068-2-1; PN-EN 1708-1:2002; PN-EN 1779:2002; PN-
EN1289:2000; PN-EN 1011-1; IEC 68-2-30: Test Db,variant 1; PN-M-42370

Compliance with the principal requirements was confirmed by accredited
laboratories and offices:

Polskie Centrum Badań i Certyfikacji S.A. [Polish Centre for Testing
and Certification] , ul. Kłobucka 23A, 02-699 Warsaw, Poland

Przemysłowy Instytut Elektroniki [Industrial Institute of Electronics], ul. Długa
44/50, 00-241 Warsaw, Poland

Główny Urząd Miar Jednostka Certyfikująca [Central Office of Measures,
Certificating Unit] , ul. Elektoralna 2, 00-950 Warsaw, Poland

SONIX® Industrial Electronic Devices ul. Leopolda
Lisa-Kuli 12, 05-270 Marki phone number +48 22-
7811133, fax number +48 22-7811644
sonix@medianet.pl

GUARANTEE CERTIFICATE

1. The producer guarantees good quality of the product and its meeting the parameters defined in the User's Instructions.
2. The guarantee period covers 12 months from the date of sales or 18 months from the date of start-up done by SONIX but not more than 24 months from the date of sales.
3. The free of charge guarantee repair shall be done within 48 hours from delivering the product to the producer's or within 14 day from filing a complaint.
4. The producer undertakes to perform post-guarantee repairs within the dates specified in point 3.
5. The guarantee shall not remain valid in the case of:
 - mechanical damage to the product
 - interferences to the inside of the product except for the cases defined in the Instructions for Assembly and Operating
 - exploitation incompliant with the Instructions for Assembly and Operating
6. The guarantee does not cover complaints relating to incorrect working caused by external factors and not by damage of the product (e.g. the probes' surface covering with deposit, presence of air in the pipeline, exceeding the temperature limit for the work of ultrasound probes etc.).

Name of the product: ULTRASOUND FLOWMETER, type: SONIX 10D
READING PANEL, type: SONIX P5

Purchasing party:.....

Factory numbers:

The SONIX 10D Flowmeter.

The SONIX P5 Reading Panel.

Date of sales:.....

